

SensLights Model Specification	SLL 1720 B Ceiling Mount Sensor
Power Supply	AC 110V~240V
Power Frequency	50 ~ 60Hz
Rated Load	1200 W (110V /AC 400W)
Ambient Light	< 10 LUX ~
Sensing Angle	120 to 360 degrees
Sensing Distance	24° C < 6 meters
Time Delay	5 sec~ 8Mni
Work Temperature	-20 ~ +50 °C
SensLights Power Consumption	0. 45 w (working) 0.1 W (static)
IP	44
Installation Height	2 -4 M
Weight	90g
Detection Moving Speed	0.6 ~ 1.5 m/s
Working Humidity	<93 % RH
Illumination Location	Hall, Passage, Corridor, backyard, garage, stairs, balcony, fence gate etc..
Notes	1. Avoid sunshine or being against draft outlet of air-con and vent for the installation location.



SLL1720B infrared automatic switch!

SensLights

The product is a new energy-saving switch, it adopts integrated circuit and the good sensitivity detector. It incorporates automatism, convenience, energy-saving, safety and practicality. It works by receiving human motion infrared rays. It can start the controlled load at once when one enters detection field. It can identify day and night automatically. Its installation is very convenient and using range is wide. It has the functions of power indication and detection indication.

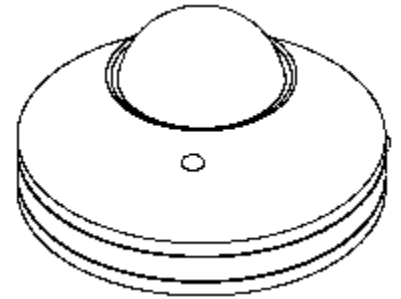

SPECIFICATIONS:

Power source: 220-240V/AC
100-130V/AC

Power frequency: 50/60Hz

Rated load: 1200W Max.tungsten (220-240V/AC)
120W Max. fluorescent (220-240V/AC)
800W Max.tungsten (100-130V/AC)
80W Max.fluorescent (100-130V/AC)

Time setting: Min: 5sec Max: 6min±1min

Light-control: <10LUX

Detection range: 6m Max (24°C)

Detection angle: 120°(side view)
360°(top view)

Working temperature: -10°C~+40°C

Working humidity: <93%RH

Installation height: 2m~4m

Power consumption: 0.5W (static 0.1W)

Detection speed: 0.6 ~1.5m/s

FUNCTION:

- Can identify day and night automatically: The ambient-light can be adjusted freely according to consumers desire when SLL 1720B works. It can work in the daytime and at night when you turn the switch to the "TEST" position. It can work only in the less than 10LUX ambient-light when you turn it to the "2", "3", "4" position. As for the adjustment pattern, please refer to the testing pattern.
- Power and detection indication: The indicator lamp is green when you switch on the power and it is red when sensor receives the induction signals. So it can show if the power and detection are normal.
- Time-delay is adjustable: time-delay can be set freely according to consumers desire. Turn the switch clockwise. The "1" position (the minimum time) is about 5sec. "2" position is about 30sec, "3" position is 2min±30sec, "4" position is 6min±1min.



Correct moving orientation



Incorrect moving orientation



SensLights **INSTALLATION**:(see the following figure)

- Switch off the power.
- Turn clockwise the bottom-stand and take off it. The power wire cross the hole in the middle of bottom-stand.
- The bottom-stand is fixed on the selected position with inflated screw.
- Connect the power and the load into the connection-wire column of the sensor according to connection-wire diagram.
- The sensor aimed at the mouth of bottom-stand and turned anti-clockwise.
-

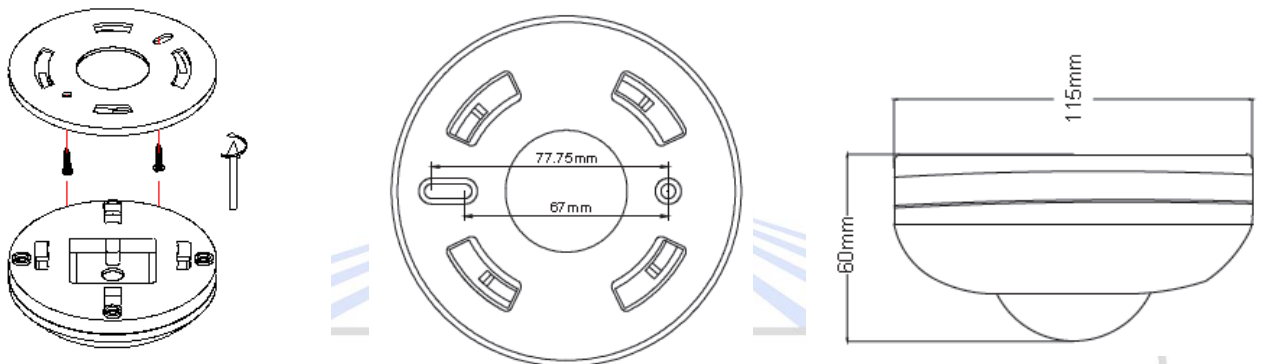

CONNECTION-WIRE DIAGRAM

(see the right figure)

TEST:

- Turn the switch to the "1" position,
- After switching on the power, the controlled load shouldn't work and the indicator lamp is green, after 5~10sec, the load should work and the indicator lamp is red. Under the no inductor signals condition, the load should stop working within 5~30sec. The indicator lamp is still green.
- After the first is out, make it sense again after 5~10sec, the load should work and the indicator lamp is red. The load should stop working within 5~15sec.
- Turn the switch to the "2" position. The inductor load shouldn't work in the ambient-light more than 10lux. If you cover the detection window with the opaque objects (towel etc), the load should work. Under the no inductor signals condition, the load should stop working within 25~35sec.

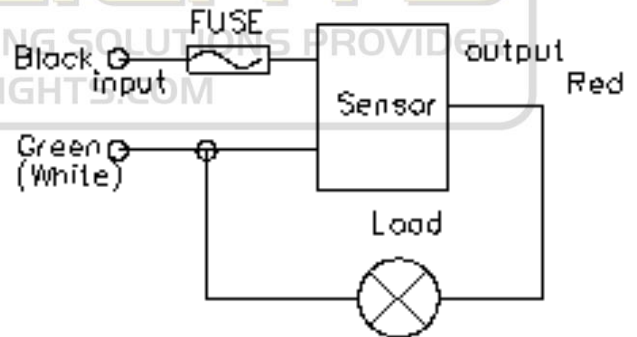

NOTES

- Electrician or experienced human can install it»
- The unrest objects cant be regarded the installation basis-face»
- In front of the detection window there aren't hinder or unrest objects effecting detection.
- Avoid installing it near air temperature alteration zones for example: air condition, central heating, etc
- Please don't open the case for your safety if you find the hitch after installation.
- If there are some difference between instruction and the function the product has, please give priority to product and sorry not to inform you additionally.

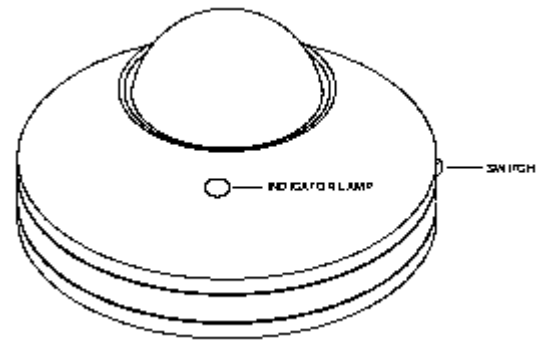
**SOME PROBLEM AND SOLVED WAY SensLights**

- The load don't work
 - a. Check the power and the load»
 - b. If the load is good»
 - c. If the indicator lamp is green;
 - d. Please check if the working light correspond to the ambient light;
- The sensitivity is poor
 - a. Please check if in front of the detection window there is hinder that effect to receive the signals;
 - b. Please check the ambient temperature;
 - c. Please check if the signals source is in the detection field;
 - d. Please check the installation height;
 - e. If the moving orientation is correct.
- The sensor cant shut automatically the load:
 - a. If there are continual signals in the detection fields;
 - b. If the time delay is set to the longest;
 - c. If the power correspond to the instruction.
 - d. If the air temperature change near the sensor, for example air condition or central heating etc.

Sensor information

(Height of installation2~4M)

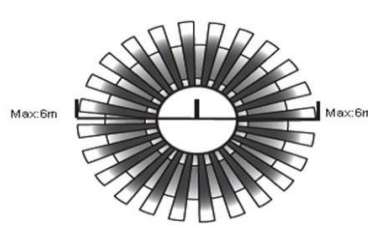
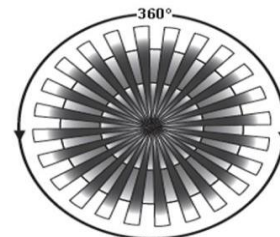
(Height of installation2~4M)
Sensing distance adjustment range

Sensing angle adjustment range

