

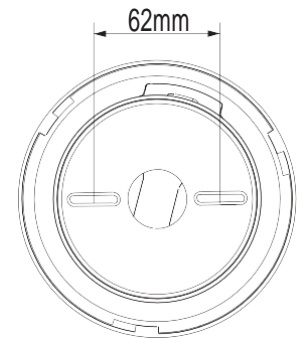

SensLights Model Specification	SLL 1225B Ceiling Mount Sensor
Power Supply	AC 100V~240V
Load	3000W Max.tungsten 1000W Max.fluorescent
Power Consumption	0.45W(static 0.1W)
Sensing Angle	25° C < 360 degrees
Sensing Distance	25° C max < 15 meters
Time-delay	(8±3)S-(6±0.5)Min (adjustable)
Light-control	<10LUX~daylight (adjustable)
Preparation	After electrifying up to the light flushes 3 times
Weight	150g
Wiring	2IN / 2OUT
Installation height	2.5-3.5m
Temperature & humidity	<93% HR / 20°c- 40°c
Detection Motion Speed	0.6-1.5m/s
Illumination Location	Corridor, Hall , backyard, garage, stairs, balcony, Rooms
Notes	1. Avoid sunshine or being against draft outlet of air-con and vent for the installation location.

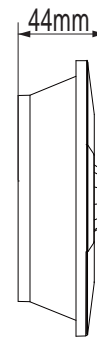

SLL1225 B Infrared Sensor Instruction

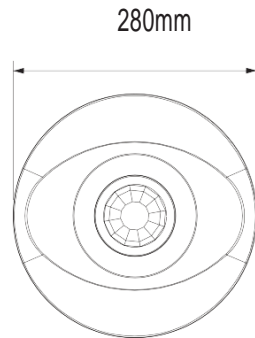

Product information

The product is a PIR sensor switch, utilizes the infrared energy from human as control-signal source and determine the light to need to work or not, and control the light on and off automatically .When one enters the detection filed and trigger the sensor to work ,the light turns on; when one leaves the detection filed and the setting time reaches, the light will turn off.It can detect the ambient light illumination automatically and set and adjust the value according to the fact need. Such as, the light will turn on and works when the ambient light illumination is under setting value. once it exceeds the setting value, the light will stop working.The light will be on until the time-delay comes when the sensor is triggered. Once detected the constant signal, the time will be overlaid and the light will be on constantly.It can be installed in indoor, corridor and public-building.

Specifications

Power source: 220-240V/AC
 Power frequency: 50Hz
 Rated load: 3000W Max.tungsten
 1000W Max.fluorescent
 Time setting: (8±3)S-(6±0.5)Min (adjustable)
 Light-control: <10LUX~2000LUX (adjustable)
 Detection range: 3-8m Max (radii.) (adjustable)

Detection angle: 360°
 Installation height: 2.5m~3.5m
 Working temperature: -10~+40°C
 Detection motion speed: 0.6~1.5m/s
 Working humidity: <93%RH
 Standby power: 0.45W(static 0.1W)

Sensor information

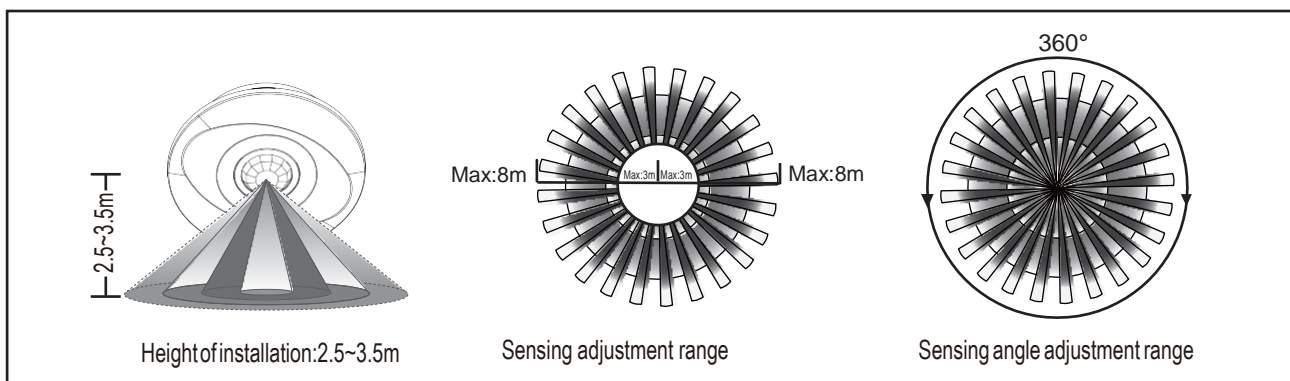

Function

- Detection field: the detection field is made up of up and down, left and right service field, it can be selected according to the consumer's desire. But the moving orientation has great relationship with the sensitivity.
- Can identify day and night: the light control can be adjusted freely when it works. It can work in the daytime and at night when it is adjusted on the "sun" position (max); but it can only work in the light control less than 10lux when it is adjusted on the "moon" position (min). As for the adjustment pattern, please refer to the testing pattern.
- Time delay can be added continually: when it received the second induction signal after the first it will compute time once more on the rest of the first time delay basic.(Set time)
- Light-control potentiometer (LUX): clockwise the knob to increase its value; anti-clockwise the knob to decrease its value.
- Time potentiometer (TIME): clockwise the knob to increase its value, the maximum delay time is (6 ± 0.5) minutes; anti-clockwise the knob to decrease its value, the minimum delay time is (8 ± 3) seconds.
- Sensitivity potentiometer (SENS): clockwise the knob to increase its value, the maximum distance is 8m; anti-clockwise the knob to decrease its value, the minimum distance is 3m.

Connection-wire diagram

L Brown
N Blue L'
Red

connect L and N with power;
connect N and L' with load.

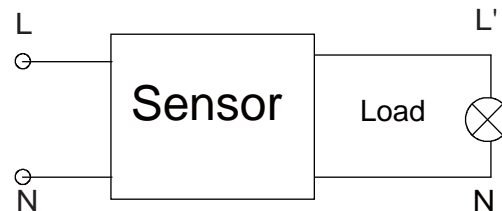

Fig.1

Procedure of installation

- Turn off the power.
- Knock the plastic expansion screw into the hole which you drill and fix the base of the product on the selected place with the screws. (as fig.2)
- Connect the power into the connection-wire column of the sensor according to connection-wire diagram.
- Fix the sensor on the base with the screws (as fig.3)
- Put the top cover on the sensor, turn it clockwise and you will hear "bong" and switch on the power to test.
- Installation is ok.

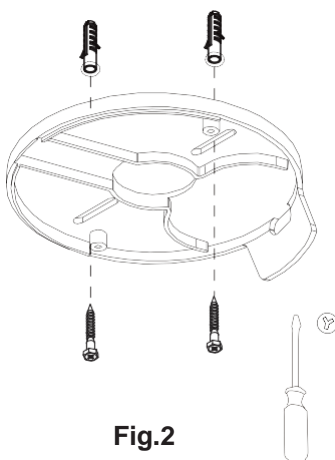

Fig.2

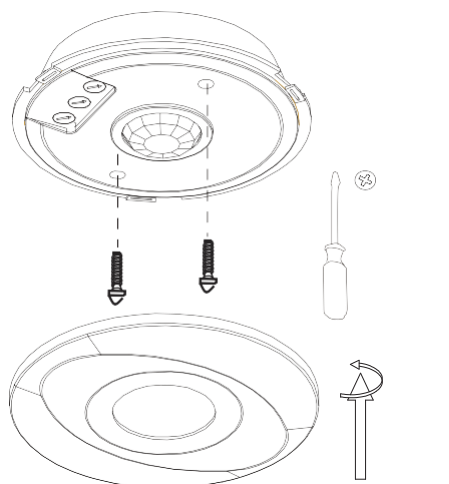

Fig.3

turn it clockwise

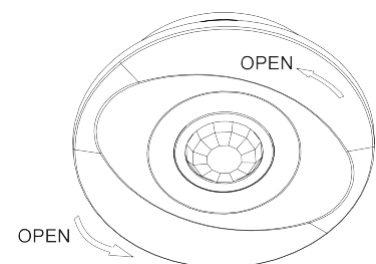

Fig.4



Test

1. Turn the light-control potentiometer clockwise to Maximal value, the time delay potentiometer counterclockwise to Minimal value, the sensitivity potentiometer clockwise to Maximal value.

First step: Start the sensor ceiling test under the greater than 1000 LUX environment (daytime). People walk horizontally in the 8 meters area, then the sensor will start load to work when it has detected the signal. And then people stop moving, the load will stop working in $8 \pm 3S$.

Second Step: Repeat the first step under the the less than 10 LUX environment (night). The sensor starts to detect.

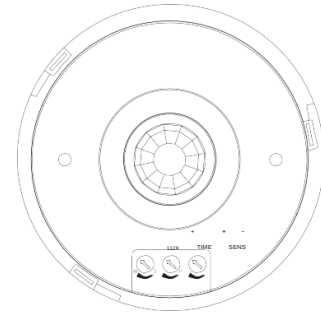

Fig.5

2. Turn the light-control potentiometer counterclockwise to Minimal value (night mode), the time delay potentiometer clockwise to Maximal value, the sensitivity potentiometer counterclockwise to Minimal value.

First step: Start the sensor ceiling test under the greater than 1000 LUX environment (daytime). People walk horizontally in the 3 meters area, then the sensor will not detect. And then people stop moving, the load will stop working in $8 \pm 3S$.

Second Step: Start the sensor ceiling test under the less than 10 LUX environment (night). People walk horizontally in the 3 meters area, then the sensor will start load to work when it has detected the signal. And then people stop moving, the load will stop working in $6 \pm 0.5Min$.

ATTENTION: When use this product, please adjust the sensitivity to an appropriate position you need, please do not adjust the sensitivity to maximum, to avoid the product does not work normally caused by wrong motion. Because the sensitivity is too high easily detect the wrong motion by wind blowing leaves & curtains, small animals, and the wrong motion by interference of power grid & electrical equipment. All those lead the product does not work normally !

When the product does not work normally, please try to lower the sensitivity appropriately, and then test it.

Pay attention to installation

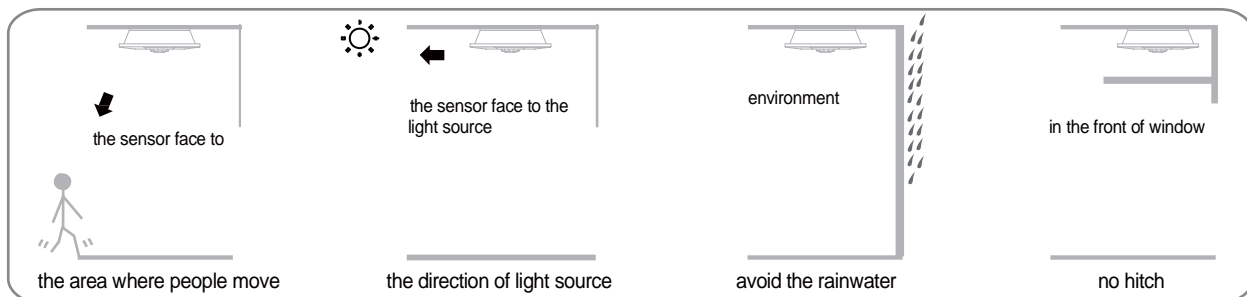
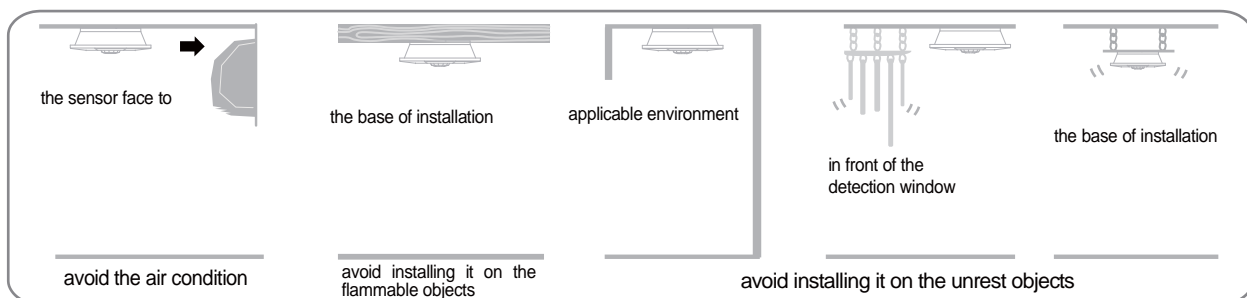

Notes

- Electrician or experienced human can install it.
- The unrest objects can't be regarded the installation basis-face.





- In front of the detection window there should be no hinder or unrest objects effecting detection.
- Avoid installing it near air temperature alteration zones for example: air condition, central heating, etc.
- Please don't open the case for your safety if you find the hitch after installation.

Remark

1. Keep the sensor face to the area where human usually move.
2. Keep the sensor face to the position of the ambient light in order to get much more exact illuminance setting.
3. If detect the signal again within the time-delay, the time-delay will be over lied.
4. LUX knob: the luminance of working conditions . When the knob switches ☀️ , it means it can detect all day, when the knob switches 🌙 , it will only work below the luminance <10 LUX.
5. TIME knob: It is a period that the light turns on slowly to no any signal gradually, till out of work.

Some problem and solved way

- The load don't work:
 - a: Check the power and the load.
 - b: If the load is good.
 - c: Please check if the working light correspond to the ambient light.
- The sensitivity is poor:
 - a: Please check if in front of the detection window there is hinder that effect to receive the signals.
 - b: Please check if the ambient temperature is too high.
 - c: Please check if the signals source is in the detection fields.
 - d: If the moving orientation is right.
- The sensor can't shut automatically the load:
 - a: If there is continual signal in the detection fields.
 - b: If the time delay is set to the longest.
 - c: If the power correspond to the instruction.
 - d: If the air temperature change near the sensor, for example air condition or central heating etc.

Warning!

- When used in different environments, please do not to adjust the sensitivity to the highest. Because that could easily lead to malfunction.
- Please confirm with professional installation.
- Please cut off power supply before installation and removal operations.
- Make sure that you have cut off the power for safety purposes.
- Improper operation caused losses, the manufacturer does not undertake any responsibility.

We are committed to promoting the product quality and reliability, however, all the electronic components have certain probabilities to become ineffective, which will cause some troubles. When designing, we have paid attention to redundant designs and adopted safety quota to avoid any troubles.

This instruction, without our permission, should not be copied for any other purposes.

